

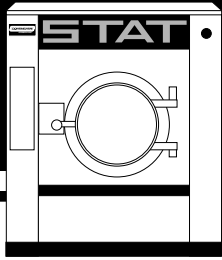

**GIRBAU, INC.**

2500 State Road 44 • Oshkosh, WI 54904  
 (920) 231-8222 • FAX (920) 231-4666  
 www.cont-girbau.com



# H2255

**HIGH-PERFORMANCE  
 WASHER-EXTRACTOR**

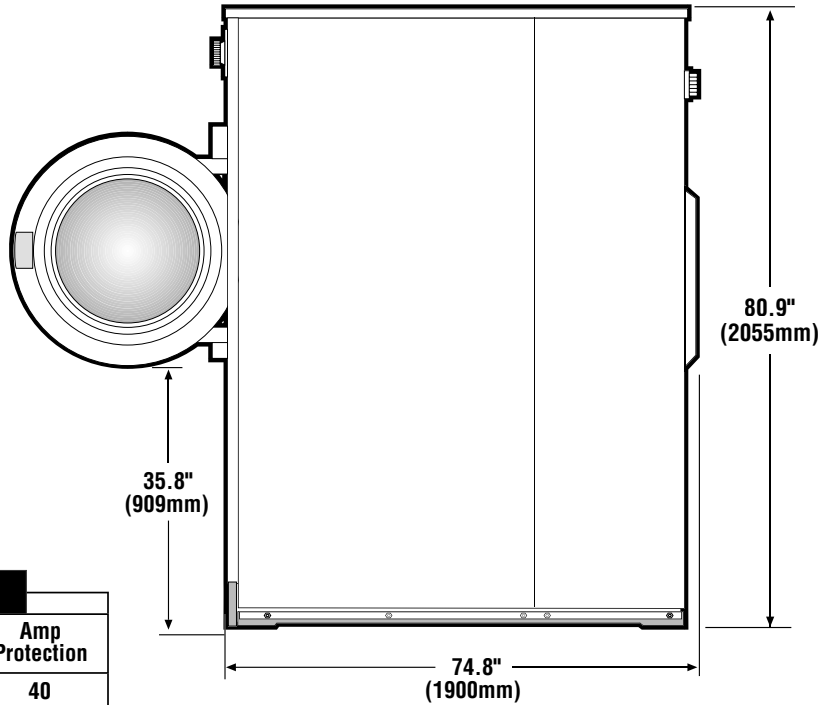

Electrical Data		
Voltage	Wire Config.	Amp Protection
208-240/60/3	3W+G	40
440/60/3	3W+G	20

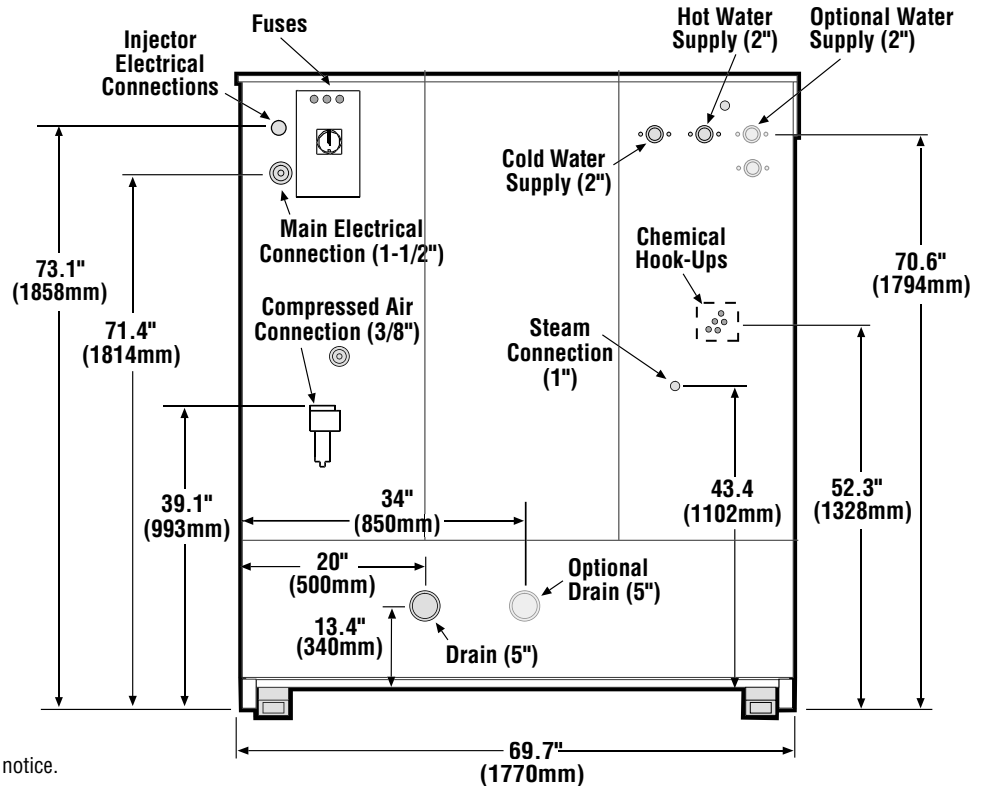

\*Specifications subject to change without notice.

## H2255 Product Technical Specifications

Capacity	255 lbs.	(110 kg.)
Cylinder Diameter	51.5 in.	(1310 mm.)
Cylinder Depth	32 in.	(816 mm.)
Cylinder Volume	38.9 cu. ft.	(1100 dm <sup>3</sup> )
Crated Weight	9654 lbs.	(4379 kg.)
Net Weight	8840 lbs.	(4010 kg.)
Height	80.9 in.	(2055 mm.)
Overall Depth	74.8 in.	(1900 mm.)
Width	69.7 in.	(1770 mm.)
Floor to Door (h)	35.8 in.	(909 mm.)
Washing Speed	11-31 rpm	
Spin Speeds	50/360/480/610/720 rpm	
G-Force	1.8/95/169/273/380	
Drain Diameter	5 in.	(127 mm.)
Water Inlets	2 in.	(51 mm.)
Water Pressure	7-87 PSI	(0.5-6 bar)
Water Flow	58 gal/min.	(220 l/min.)
Steam Connection	1 in.	(25.4 mm.)
Steam Pressure (optional)	29-87 PSI	(2-6 bar)
Steam Flow (optional)	794 lbs/h	(360 kg/h)
Compressed Air Connection	3/8 in.	(10 mm.)
Compressed Air Pressure	98 PSI	(7 bar)
Compressed Air Flow	0.71 cfm	(20 l/min.)
Motor Power	11 kVA	
Shipping Dimensions (W x D x H)	78.3 x 82.7 x 87.8 in.	(1990 x 2100 x 2230 mm.)

## Chemical Hook-Up Information

TERMINAL CONNECTIONS ALL MODELS		CHEMICAL INJECTION (Dosing)
		PM MODEL TERMINAL CONNECTIONS
Supply #	Conn. #	
5	X5-6	47
4	X5-5	46
3	X5-4	45
2	X5-3	44
1	X5-2	43
Common	X5-1	207





**GIRBAU, INC.**

2500 State Road 44 • Oshkosh, WI 54904

(920) 231-8222 • FAX (920) 231-4666

www.cont-girbau.com

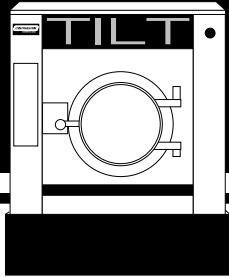

# H2255 tilt

**HIGH-PERFORMANCE  
WASHER-EXTRACTOR**

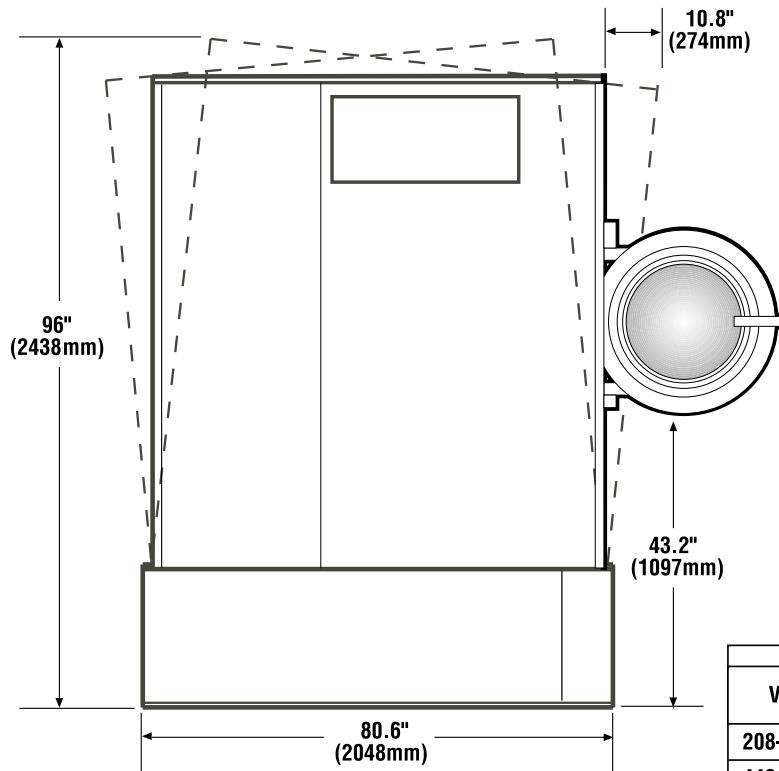

**Electrical Data**

Voltage	Wire Config.	Amp Protection
208-240/60/3	3W+G	40
440/60/3	3W+G	20

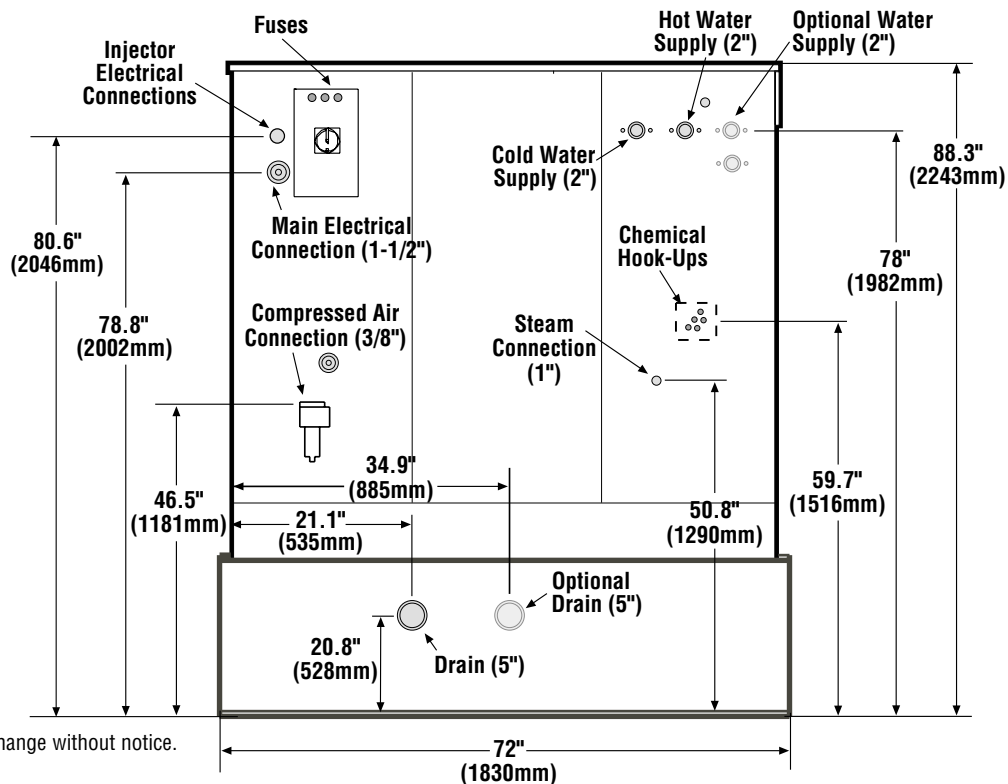

\*Specifications subject to change without notice.

## H2255 tilt Product Technical Specifications

Capacity	255 lbs.	(110 kg.)
Cylinder Diameter	51.5 in.	(1310 mm.)
Cylinder Depth	32 in.	(816 mm.)
Cylinder Volume	38.9 cu. ft.	(1100 dm <sup>3</sup> )
Crated Weight (Total of Machine Crate and Tilt Crate)	10787 lbs.	(4893 kg.)
Net Weight	9766 lbs.	(4430 kg.)
Height	88.3 in.	(2243 mm.)
Overall Depth	80.6 in.	(2048 mm.)
Width	72 in.	(1830 mm.)
Floor to Door (h)	43.2 in.	(1097 mm.)
Washing Speed	11-31 rpm	
Spin Speeds	50/360/480/610/720 rpm	
G-Force	1.8/95/169/273/380	
Drain Diameter	5 in.	(127 mm.)
Water Inlets	2 in.	(51 mm.)
Water Pressure	7-87 PSI	(0.5-6 bar)
Water Flow	58 gal/min.	(220 l/min.)
Steam Connection	1 in.	(25.4 mm.)
Steam Pressure (optional)	29-87 PSI	(2-6 bar)
Steam Flow (optional)	794 lbs/h	(360 kg/h)
Compressed Air Connection	3/8 in.	(10 mm.)
Compressed Air Pressure	98 PSI	(7 bar)
Compressed Air Flow	7.1 cfm	(200 l/min.)
Motor Power	11 kVA	
Shipping Dimensions (W x D x H)	78.3 x 82.7 x 87.8 in.	(1990 x 2100 x 2230 mm.)

## Chemical Hook-Up Information

TERMINAL CONNECTIONS ALL MODELS		CHEMICAL INJECTION (Dosing)
		PM MODEL TERMINAL CONNECTIONS
Supply #	Conn. #	
5	X5-6	47
4	X5-5	46
3	X5-4	45
2	X5-3	44
1	X5-2	43
Common	X5-1	207

